

METHODS AND RESULTS OF THE RESEARCH OF THE FERTILIZER DISTRIBUTOR OF CUTTER-RIDGER-FERTILIZER

*S.O.Nukeshev, N.N.Romanyuk,
K.J.Yeskhozhin, A.E.Zhunusova*

Annotation

For a solution of the problem of even dosing of fertilizers the seed distributor for introduction of the main dose of the organic fertilizers is offered. Receiving a dosing stream of fertilizers is carried out due to the application of a spring spiral and a segment reflector established over a seeding window. As a result of pilot studies the diameter of a screw spiral, the number of threads of spirals and the number of ripples of a reflector are determined.

Keywords: fertilizer distributor, mineral fertilizers, fertilizer, helical spiral, unevenness of seeding

Introduction

The analysis of the existing designs of seed distributors shows that the spring spiral can be applied both as a vault destructor and a seed distributor. The important indicator of its work is the transporting ability, which allows to give fertilizers to seeding windows continuously, at the same time fertilizers are transported to a final window on the screw line with a certain tilt angle that results in constancy of delivery and solves a delivery pulsation problem. The arrangement of spring spirals over seeding windows allows them to perform the functions of a sieve too [1].

The first idea of transportation of cement and concrete mixes by the rotating cylindrical screw spiral placed in a flexible casing belongs to G. Plust and F. Ahrens who in 1926 declared and in 1928 took out the

patent [2] for the specified type of the screw conveyor. The subsequent domestic and foreign inventions on the one-spiral flexible screw extended the field of its application to various branches of the national economy, but flexible screws found the main application in the field of agricultural production where they are used for moving materials in the horizontal, vertical, inclined directions and for dosing [3, 4, 5].

Application of a spring spiral as the fertilizer distributor showed the positive qualities of a spiral (the prevention of vault formation, insignificant sticking of mineral fertilizer, etc.). A. I. Mordukhovich and A.E. Tompakov, investigating the device TVP-2 with the spring dosing elements, noted, “that the device provides high quality of sowing. It sows out not only damp fertilizers and

their mixes well enough, but also carefully crushes packed mineral fertilizer, and the device with a step of a spring 18, 19 mm does it better; the spring with a big step is easier, it is more elastic that positively affects self-cleaning as a result of vibration” [6, 7].

The analysis of possible solutions of a problem of

Materials and methods of research

The offered device includes the bunker 1 of a corn planter in the form of a truncated cone, in the lower compartment of the bunker there is a seeding window 2, the quantity of coming fertilizer from the bunker to a batcher 3 is regulated by a gate 4, with an adjusting scale of installation of seeding material norm. The batcher 3, represents the helical elastic body :

$$L = p r a / 180 ^{\circ},$$

where L is the length of an arch, m ; r is the radius of a circle, m ; α is the central corner in degrees.

The device for even distribution and dosing of dry fertilizer works in the following way. Fertilizer spontaneously comes from the bunker 1 through a seeding window 2 to the spiral batcher 3. The batcher 3, rotating, transports the fertilizer to a discharge opening 7, at the same time the segment reflector 6 evenly distributes fertilizer on mineral fertilizer conductors 8.

The seed distributor will be installed on a cutter-ridger-fertilizer

development of the seed distributor for surface introduction of the main dose of fertilizers in tilling potatoes revealed the expediency of using for this purpose the above mentioned effects of screw spirals in the course of their movement to seeding windows.

fixed on a shaft 5 drive of the seed distributor on which the conic segment reflector 6 with discharge opening 7 and mineral fertilizer conductor 8 are fixed, figure 1.

The segment reflector 6 represents a cone with ripples, the form of which is described by a formula

which will be developed on the base of the tilled cutters.

A number of domestic and foreign works [1-7], etc. are devoted to the pilot study of the process of distributing fertilizers by screw distributing devices therefore a certain positive experience is accumulated in the method of carrying out experiments. Besides, there is a big field experience in operation of screw conveyors. All this was carefully studied and taken into consideration when developing the method of pilot studies.

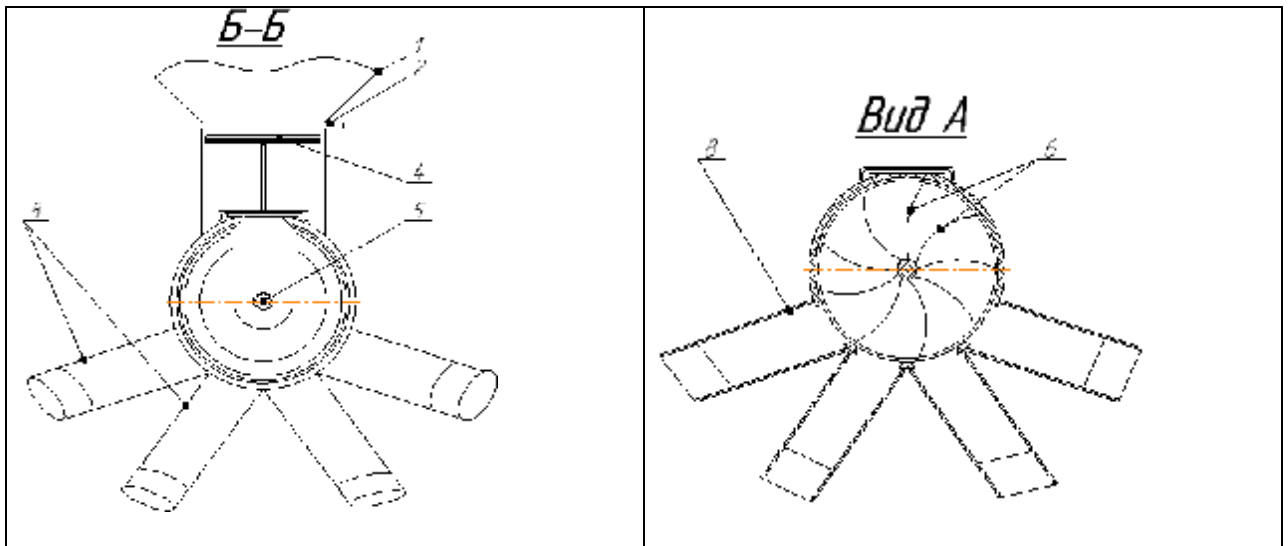
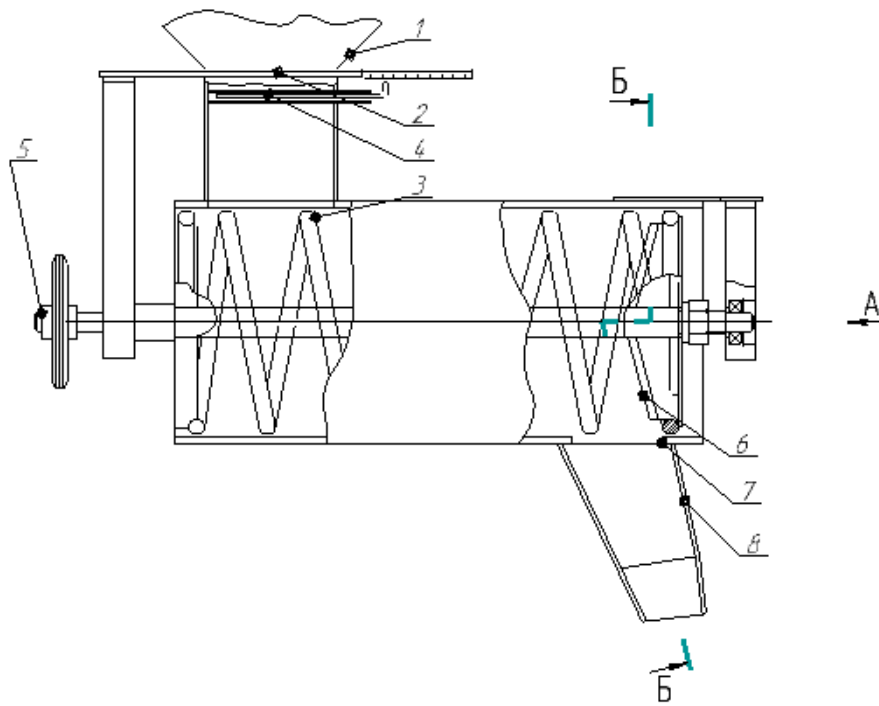

Figure 1 – The constructive scheme of the experimental seed distributor

Proceeding from the general research problems it is experimentally necessary to determine optimum constructional and kinematic parameters of the spring fertilizer distributor.

For solution of the assigned task, some experiments on the designed and made installation were carried out, figures 2-4.

Design features of the studied fertilizer distributor. The

experimental model of the spring dosing device is made in the form of a spiral elastic body of compression and fixed on a horizontal shaft, which is installed in the cylindrical case of the seed distributor where a conic segment reflector is fixed too. Doing rotary motions, giving fertilizers to the segment reflector the dosing device (spring) simultaneously interferes with direct hit of lumps in seed openings, figure 2.



Figure 2 – Fertilizer distributor in unassembled form



Figure 3 – Fertilizer distributor in assembled form



Figure 4 – The seed distributor fixed under the bunker

Description of the experimental installation. A laboratory installation was made for laboratory testing of the experimental machine on detection of dependences of quality indicators of its work on constructional and technological parameters of the sowing system.

Laboratory installation consists of a frame where a fragment of the

grain tank with the seed distributor, the running tape are installed, figure 5. Fertilizer distributors receive the drive, which allows to change continuously the frequency of rotation and has the device for measurement of their value. For the endless streaming tape a separate drive is mounted.



Figure 5 – Laboratory installation

In laboratory experiments of frequency of rotation of the fertilizer distributor coil and drum of the streaming tape were measured by tachometer, time was measured by a stop watch and fertilizers were weighed on scales CAS MW-II – 300 BR accurate within 0,005 gr.

For the criterion of optimization unevenness of seeding between

devices and instability of seeding were taken, which characterize the quality indicators of work.

A priori it is known that the quality of operation of the fertilizer distributor depends on its constructional and technological parameters, which were chosen as the major operated factors:

- outer diameter of a spring is $D=60$ mm;
- the number of threads of a spring is 2 pieces;
- the number of ripples of a segment reflector – 8 pieces.
- a gap between the coil and the bottom is d mm.

There are also other important factors which exert a great influence on a mechanical sowing of mineral fertilizers [8-10]. It is humidity, particle-size distribution of the sowed fertilizers. They are set by the manufacturing plant; their levels depend on storage conditions and other reasons. It is difficult to operate these factors and therefore during the experiment they were stabilized at some level.

For carrying out an experiment the fertilizer distributor with characteristics in accordance with a matrix of planning of the experiment was installed and the bunker was filled up with fertilizer. The drive of

Results and discussion

Search experiments were carried out for determining the extent of influence of characteristics on the quality indicators of operation of the fertilizer distributor for mineral fertilizers. They show that the main indicators of the quality of operation of the experimental fertilizer distributor – unevenness of seeding between the devices H_1 and instability of seeding H_2 change with the alteration of condition of carrying out experiments, i.e. variation of design and technological characteristics leads to change of optimization characteristics. All coefficients are

the seed distributor was turned on. After the achievement of the set mode of seeding, a special ware for grain conductor was placed. Seeding lasted within one minute. The sowed portions were weighed on scales to 0,01 gr. The necessary amount of frequency was fixed for ensuring reliability of the experiments of laboratory researches with an error of 5-10%, under the probability 0,9-0,95.

Processing of results consisted in defining unevenness of seeding between devices and instability of seeding by the method of variation statistics. Unevenness of seeding between devices means the coefficient of a variation of the fertilizers mass that comes to separate sheets installed on the total width perpendicularly to the direction of the movement. And instability of seeding means the coefficient of a variation of average mass of fertilizers, sowed for frequency.

significant, except ϵ_2 , ϵ_4 and ϵ_5 , ϵ_6 as on an absolute value they are less than confidence interval. It means that the factor ϵ_4 is a gap within the indicated variation limits does not influence on unevenness and instability of seeding therefore this factor needs to be eliminated from among input parameters and when it is recorded at zero level – 6 mm.

The difference between values of optimization parameters in the center of the plan and the sizes of the free member ϵ_0 is

$$|\bar{y}_{\phi} - \epsilon_{\phi}| = |3,05 - 5,801| = 2,751$$

$$|\bar{y}_{\psi} - \epsilon_{\psi}| = |2,12 - 5,350| = 3,23$$

it is much more than S_y experiment error:

$$S_{\phi} = \pm \sqrt{S_{y_{\phi}}^2} = 0,294; \quad S_{\psi} = \pm \sqrt{S_{y_{\psi}}^2} = 0,301.$$

Consequently, the effects of interaction of factors significantly differ from zero and the studied dependences cannot be approximated, with a sufficient accuracy, by a polynomial of the first degree. On the basis of it for obtaining dependences of unevenness of seeding between devices and instability of seeding from constructional and technological data of the skilled sowing system, it is necessary to pass to planning of the second order.

Pilot studies for the choice of optimum constructive and technological parameters of the

fertilizer distributor were carried out when seeding the granulated mineral fertilizer "superphosphate" with a satisfactory spread which is applied to the main, pre-sowing and local introduction into rows in sowing. In the bunker of experimental installation the spring working body with optimum parameters was installed. Conditions and data of experiments are given in table 1.

The experiment was carried out according to the program of the central composite rotatable planning of the second order. The equations of regression have a form:

for unevenness of seeding between devices:

$$Y_1 = 3,549 + 0,241x_1 + 0,102x_2 - 1,640x_3 + 0,96x_1x_2 - 0,687x_1x_3 - 0,275x_2x_3 + 0,379x_1^2 + 0,651x_2^2 + 2,271x_3^2; \quad (1)$$

for instability of seeding:

$$Y_2 = 4,12 + 0,322x_1 + 0,158x_2 - 0,336x_3 + 0,462x_1x_2 + 0,275x_1x_3 - 0,671x_2x_3 + 0,789x_1^2 + 0,594x_2^2 + 0,487x_3^2; \quad (2)$$

For verification of adequacy of the received models by means of F-criterion were calculated:

$$\begin{array}{lll} S_{ag_1}^2 = 0,0924 & S_{y_1}^2 = 0,032 & F_{p_1} = 2,88 \\ S_{ag_2}^2 = 0,0995 & S_{y_2}^2 = 0,0218 & F_{p_2} = 3,56 \end{array}$$

Tabulated value of FT-criterion at 5% significance level and number of degrees of freedom $f_{a\partial} = 5$ and $f_E = 5$ is equal to 5,05.

The value of $F_P < F_T$, therefore the hypothesis of models adequacy can be taken as right with 95% confidence.

Table 1 - Matrix of planning and results of the experiments

Fertilizer distributor		Entrance factors			Optimization parameter	
Natural		Spring diameter D mm	Number of spring threads n piece	Number of reflector ripples m piece	Unevenness of seeding on bends $H_1, \%$	Instability of seeding $H_2, \%$
Coded		X_1	X_2	X_3	Y_1	Y_2
Levels of a variation of factors	+1,682	86,82	3,682	9,364	-	-
	+1	80	3	8	-	-
	0	70	2	6	-	-
	-1	60	1	4	-	-
	-1,682	53,18	0,318	2,636	-	-
Variation interval		10	1	2	-	-
Numbers and conditions of experiments	1	+	+	+	3,45	3,5
	2	-	+	+	9,7	9,81
	3	+	-	+	3,2	3,18
	4	-	-	+	6,5	6,7
	5	+	+	-	2,6	2,9
	6	-	+	-	9,2	10,2
	7	+	-	-	3,82	3,58
	8	-	-	-	8,6	8,3
	9	+1,682	0	0	1,3	1,1
	10	-1,682	0	0	10,4	11,5
	11	0	+1,682	0	6,3	6,1
	12	0	-1,682	0	5,0	5,4
	13	0	0	+1,682	4,8	4,6
	14	0	0	-1,682	5,9	6,3
	15	0	0	0	3,6	3,9
	16	0	0	0	3,8	3,6
	17	0	0	0	4,2	4,5
	18	0	0	0	3,7	4,4
	19	0	0	0	3,0	4,1
	20	0	0	0	3,9	4,2

Transition from coded (x_1, x_2, x_3) to natural (β, s, h) values of factors is carried out according to experimental conditions on formulas:

$$x_1 = \frac{D-60}{10}; \quad x_2 = \frac{n-2}{1}; \quad x_3 = \frac{m-4}{2}$$

It is difficult to analyze the equations of the second degree in the form of (1) and (2) therefore for receiving the idea of a geometrical image of function of a response the dependences corresponding to them by transformations were ended in a canonical form.

Unevenness of seeding between devices

$$Y_1 - 1,87 = 0,75X_1^2 + 0,723X_2^2 + 0,653X_3^2 \quad (3)$$

instability of seeding

$$Y_2 - 1,58 = 0,861X_1^2 + 0,796X_2^2 + 0,518X_3^2 \quad (4)$$

Considering the equations of unevenness of seeding between devices in a canonical form, it should be noted that surfaces of a response represent a rotation ellipsoid, has a minimum in the center of an ellipsoid

as all coefficients have positive signs. The extremum lies in the studied area that confirms the correctness of the choice of variation limits of variable factors. Coordinates of the center of a figure are equal:

$$x_{1s} = -0,506 \quad x_{2s} = 0,444 \quad x_{3s} = 0,617$$

When decoding coordinates of a special point, the natural values of factors were obtained: diameter D is 60, the number of calling is 2; the number of ripples of the reflector is 8 at the same time unevenness of seeding between devices is 1,87%.

As well after considering the equations (4) we will get the following natural values of factors in

the center of the experiment: $D - 55$ mm, $n - 2$, $m - 6$.

Instability of seeding in the center of a figure is 1,58%.

As is clear from the given results, the centers of experiments for unevenness of seeding between devices and instability of seeding are very close that facilitates search of optimum parameters.

Conclusion

Pilot studies showed the operability of the offered fertilizer distributor when seeding granulated mineral fertilizer "superphosphate", with a satisfactory spread which is applied to the main, presowing and local introduction into rows in sowing.

The analysis of the equations (1) and (2) and the combined two-dimensional sections allowed to assign the constructive parameters of the fertilizer distributor, which should have the following values: diameter D is 60, the number of threads is 2; the number of ripples of reflector is 8.

References

1 Нукашев С.О. Обоснование конструкции сводоразрушителя // Труды научно– практ. конф. «Научные основы развития сельского хозяйства». – Ташкент: ТашГАУ, 2001. –С. 242 – 243.

2 Plust H. und Ahrens F. Biegsame, in einem Schlanh arbeiten de Furderschnecke. Немецкий патент № 462082, 3 июля 1928 г.

3 Бок Н.Б., Есхожин Д.З., Байтлесов К.Б. Обоснование некоторых параметров винтовых высевяющих аппаратов // Вопросы механизации полеводства в Северном Казахстане: тр. Целиноградского сельскохозяйственного ин-та. – 1982. – Т. 8: – С. 49– 57.

4 Байтлесов К.Б. Экспериментальные исследования пружинного высевяющего аппарата // Механизация полеводства и животноводства: тр. Целиноградского сельскохозяйственного ин-та. – Целиноград, 1975. – Вып. 8, Т.13.

5 Адуов М.А. Обоснование параметров винтового высевяющего аппарата:автореф. канд. техн. наук. – Челябинск, 1987. – 18 с.

6 Мордухович А.И., Томпаков А.Е. Новые туковысевающие аппараты //Механизация и электрификация сельского хозяйства. – 1983. –№ 2. – с. 11.

7 D. Li, Y. Liu, and Y. Chen (Eds.): CCTA 2010, Part II, IFIP AICT 345, pp. 505–516, 2011.(http://link.springer.com/chapter/10.1007/978-3-642-18336-2_61)

8 Nukeshev S., Eskhozhin K., Eskhozhin D., Syzdykov D. J Braz. Soc. Mech. Sci. Eng. DOI 10.1007/s40430-016-0588-5.

9 Nukeshev S., Dzhadyger E., Gennady L., Karaivanov D., Zolotukhin E., Syzdykov D. Acta Universitatis Agriculturae et Silviculturae Mendelianae Brunensis / V.64, №1. Mendel University in Brno, Czech Republic, 2016. - P.115-122.

10 Nukeshev S., Eskhozhin D., Karaivanov D., Eskhozhin K. Bulgarian Journal of Agricultural Science. – 2014. - 20(No 6). - P.1513-1521.

Резюме

Для решения проблемы равномерного дозирования удобрений предложено высевяющее устройство для внесения основной дозы органоминеральных удобрений. Получение равномерного потока удобрений осуществляется за счет применения пружинной спирали и сегментного отражателя, установленного над высевным окном. В результате экспериментальных исследований определены диаметр винтовой спирали, количество заходов спиралей и количество рифов отражателя.

Summary

For a solution of the problem of even dosing of fertilizers the seed distributor for introduction of the main dose of the organic fertilizers is offered. Receiving a dosing stream of fertilizers is carried out due to the application of a spring spiral and a segment reflector established over a seeding window. As a result of pilot

studies the diameter of a screw spiral, the number of threads of spirals and the number of ripples of a reflector are determined.